

# TECHNICAL SERVICE BULLETIN

NO. 72 D 1



February, 1972

**SUBJECT:**

1st Motion Shaft Bush

**MODELS:**

Late 1971 and 1972 MGB

The first motion shaft bush used on the above models is 1/2" shorter than its predecessor and is not supplied with a replacement crankshaft or half engine.

Please, therefore, note the following:

| <u>Part Number</u>             | <u>Description</u>           | <u>Bush Part Number</u>    | <u>Length</u>    |
|--------------------------------|------------------------------|----------------------------|------------------|
| 12H 2524<br>48G 735 or 48G 732 | Crankshaft )<br>Half Engine) | 22H 1416 (Only)            | 1"               |
| Prior to Above<br>" "          | Crankshaft )<br>Half Engine) | 22H 1416<br>or<br>12H 1630 | 1"<br><br>1 1/2" |

**NOTE:** If bush part #22H 1416 is used on earlier crankshafts it must be inserted until it is flush with the bore face as shown at 'A'.

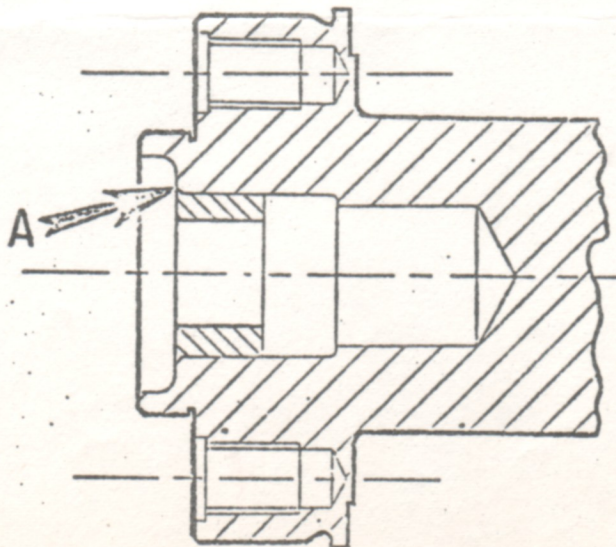

1A 177 F 95