



# Austin MG

October, 1975

SUBJECT:

MODELS:

1ST/2ND SYNCHRONIZER ASSEMBLY  
MODIFICATION

MGB

A modified 1st/2nd synchronizer assembly with reduced baulk on 1st speed gear, Part #DAM-597 has been introduced. The synchronizer and the sliding coupling are identified by offset grooves (1) which must be at the same end of the assembly. The assembly must be fitted with the groove towards the 2nd speed gear (3).

NOTE:- If a modified synchronizer is being fitted to an unmodified coupling, the coupling must be marked to indicate the grooved end of the synchronizer.

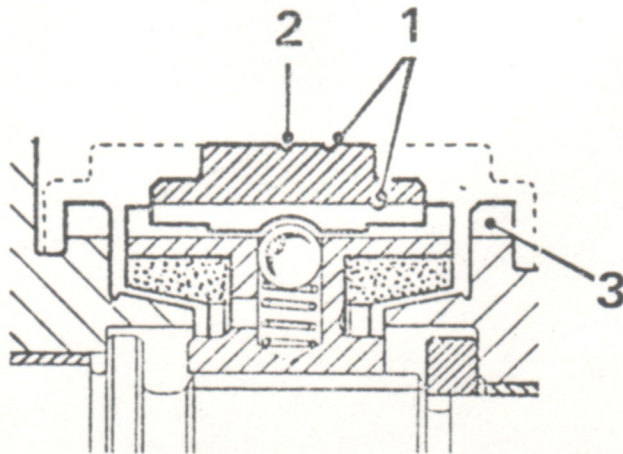

AM/TB/4/75